

# Stud Type Junction Blocks

## Single stud type junction blocks

With a maximum torque rating at 48 in-lbs, the single stud type junction blocks are ideal for heavy-duty ground or power connection points in AC or DC circuits. The modular design offers design and manufacturing flexibility with feed thru or stand alone mount options available for transformers, communication and computer power sections along with various vehicle electrical systems.

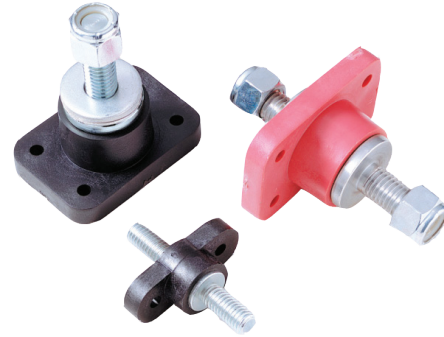

## Non feed-thru multiple stud type

Series C4559 and C6083

Rating: 30A, 600V

Temperature rating: 250°F (120°C)

Materials: Black thermoplastic with zinc-plated steel studs

Termination: #10-24 threaded studs on 0.750" centers.

Studs feature a 'dog point' to guide nut onto thread

Torque rating: 25 in-lbs max

Mounting torque rating: 24 in-lbs max

Postions: 2 - 16 positions available



Series C5237 and JB1032

Rating: UL: 30A, 300V; CSA: 30A, 600V

Temperature rating: 250°F (120°C)

Materials: Black thermoplastic with yellow zinc-plated brass studs.

Termination: #10-32 threaded studs on 0.625" centers.

Studs feature a 'dog point' to guide nut onto thread

Torque rating: 25 in-lbs max

Mounting torque rating: 24 in-lbs max

Postions: 1 - 15 positions available

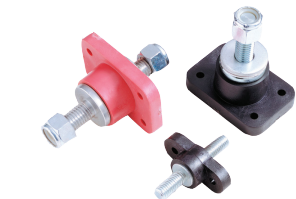

## Single stud type junction blocks

Please see the following page for specific part numbers and ordering information.



## Series C4559 and C6083

Please see the following page for specific part numbers and ordering information. Numbers and arrows molded on top of barriers indicate terminals.



## Series C5237 and JB1032

Please see the following page for specific part numbers and ordering information. Numbers and arrows molded on top of barriers indicate terminals.

## Suggested Max Termination Rating

Thread / stud size	Amperages (A)
#10	50
#1/4 & M6	100
#5/16	200
#3/8	250
#1/2	400

## Dimensions in Inches (mm)

Letters correspond to tables on following pages

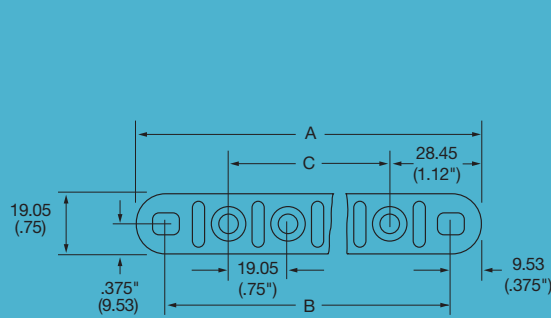
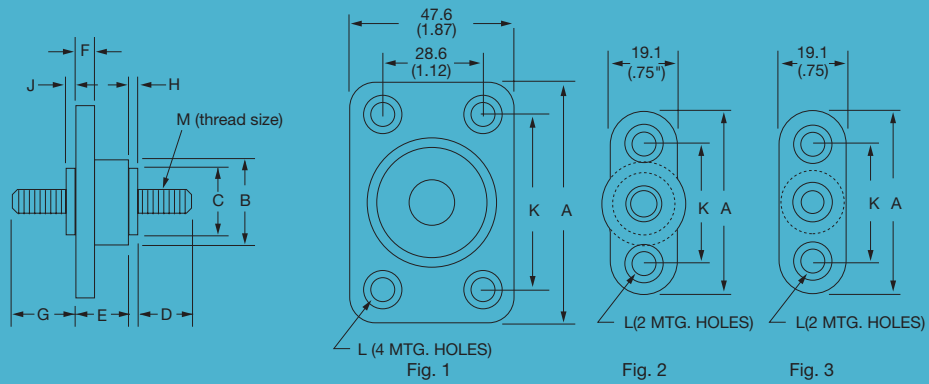

Other series available with .750" centers:

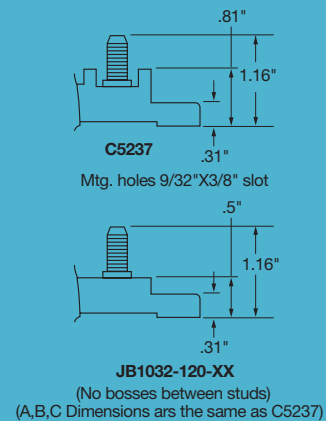
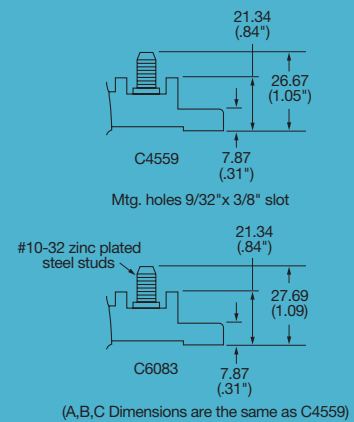
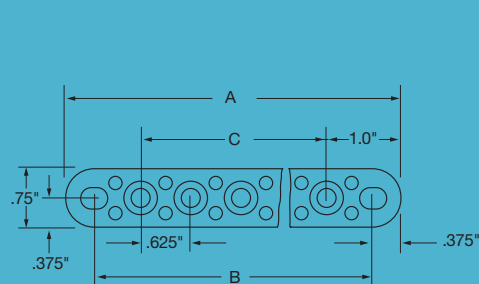

## Dimensions

Part Number	A	B	C
Series C4559			
C4559-2	3.00 (76.2)	2.25 (57.1)	0.75 (19.0)
C4559-3	3.75 (95.2)	3.00 (76.2)	1.50 (38.1)
C4559-4	4.50 (114.3)	3.75 (95.2)	2.25 (57.1)
C4559-5	5.25 (133.3)	4.50 (114.3)	3.00 (76.2)
C4559-6	6.00 (152.4)	5.25 (133.3)	3.75 (95.2)
C4559-7	6.75 (171.4)	6.00 (152.4)	4.50 (114.3)
C4559-8	7.50 (190.5)	6.75 (171.4)	5.25 (133.3)
C4559-9	8.25 (209.5)	7.50 (190.5)	6.00 (152.4)
C4559-10	9.00 (228.6)	8.25 (209.5)	6.75 (171.4)
C4559-11	9.75 (247.6)	9.00 (228.6)	7.50 (190.5)
C4559-12	10.50 (266.7)	9.75 (247.6)	8.25 (209.5)
C4559-13	11.25 (285.7)	10.50 (266.7)	9.00 (228.6)
C4559-14	12.00 (308.4)	11.25 (285.7)	9.75 (247.6)
C4559-15	12.75 (323.8)	12.00 (308.4)	10.50 (266.7)
C4559-16	13.50 (342.9)	12.75 (323.8)	11.25 (285.7)

Part Number	A	B	C
Series C5237			
C5237-1	2.00 (50.8)	1.25 (31.7)	-
C5237-2	2.62 (66.7)	1.87 (47.5)	0.625 (15.9)
C5237-3	3.25 (82.5)	2.50 (63.4)	1.25 (31.7)
C5237-4	3.87 (98.4)	3.12 (79.4)	1.87 (47.5)
C5237-5	4.50 (114.3)	3.75 (95.2)	2.50 (63.4)
C5237-6	5.12 (130.8)	4.37 (111.1)	3.12 (79.4)
C5237-7	5.75 (146.0)	5.00 (127.0)	3.75 (95.2)
C5237-8	6.37 (161.9)	5.62 (142.9)	4.37 (111.1)
C5237-9	7.00 (177.8)	6.25 (158.7)	5.00 (127.0)
C5237-10	7.62 (193.7)	6.87 (174.6)	5.62 (142.9)
C5237-11	8.25 (209.5)	7.50 (190.5)	6.25 (158.7)
C5237-12	8.87 (225.4)	8.12 (206.4)	6.87 (174.6)
C5237-13	9.50 (241.3)	8.75 (222.2)	7.50 (190.5)
C5237-14	10.12 (257.2)	9.37 (238.1)	8.12 (206.4)
C5237-15	10.75 (273.0)	10.00 (254.0)	8.75 (222.2)

## Ordering information for single stud type junction blocks

Part	Fig.	A	B	C	D	E	F	G	H	J	K	L	M	Max. Torque (in-lbs)	Material	Color
C1925*	1	2.75 (69.8)	1.5 (38.1)	1.25 (31.7)	1.25 (31.7)	1.12 (28.6)	.37 (9.5)	1.12 (28.6)	.19 (4.8)	.19 (4.8)	2.0 (50.8)	.22 Dia. w/ 44 dia. C'bore x .16 deep	1/2 - 13	300	Thermoplastic / Zinc-plated Brass	Red
C1925B*	1	2.75 (69.8)	1.5 (38.1)	1.25 (31.7)	1.25 (31.7)	1.12 (28.6)	.37 (9.5)	1.12 (28.6)	.19 (4.8)	.19 (4.8)	2.0 (50.8)	.22 Dia. w/ 44 dia. C'bore x .16 deep	1/2 - 13	300	Thermoplastic / Zinc-plated Brass	Black
C1925-1*	1	2.75 (69.8)	1.5 (38.1)	1.25 (31.7)	1.25 (31.7)	1.12 (28.6)	.37 (9.5)	1.12 (28.6)	.19 (4.8)	.19 (4.8)	2.0 (50.8)	.22 Dia. w/ 44 dia. C'bore x .16 deep	1/2 - 13	300	Thermoplastic / Tin-plated Brass	Red
C1925-1B*	1	2.75 (69.8)	1.5 (38.1)	1.25 (31.7)	1.25 (31.7)	1.12 (28.6)	.37 (9.5)	1.12 (28.6)	.19 (4.8)	.19 (4.8)	2.0 (50.8)	.22 Dia. w/ 44 dia. C'bore x .16 deep	1/2 - 13	300	Thermoplastic / Tin-plated Brass	Black
C1925-2*	1	2.75 (69.8)	1.5 (38.1)	1.25 (31.7)	1.25 (31.7)	1.12 (28.6)	.37 (9.5)	1.12 (28.6)	.19 (4.8)	.19 (4.8)	2.0 (50.8)	.22 Dia. w/ 44 dia. C'bore x .16 deep	3/8 - 16	150	Thermoplastic / Tin-plated Brass	Red
C1925-2B*	1	2.75 (69.8)	1.5 (38.1)	1.25 (31.7)	1.25 (31.7)	1.12 (28.6)	.37 (9.5)	1.12 (28.6)	.19 (4.8)	.19 (4.8)	2.0 (50.8)	.22 Dia. w/ 44 dia. C'bore x .16 deep	3/8 - 16	150	Thermoplastic / Tin-plated Brass	Black
C1933	1	2.75 (69.8)	1.44 (36.60)	1.25 (31.7)	1.5 (38.1)	1.12 (28.6)	.37 (9.5)	None	.19 (4.8)	None	2.0 (50.8)	.22 dia.	1/2 - 13	300	Thermoplastic / Zinc-plated Brass	Black
C1933-1	1	2.75 (69.3)	1.44 (36.3)	1.25 (31.7)	1.5 (38.1)	1.12 (28.6)	.37 (9.5)	None	.19 (4.8)	None	2.0 (50.8)	.22 dia.	5/16 - 18	75	Thermoplastic / Zinc-plated Brass	Black
C1938*	2	2.06 (52.4)	.94 (23.8)	.69 (17.5)	.87 (22.2)	.69 (17.5)	.31 (7.9)	.94 (23.8)	.06 (1.6)	.06 (1.6)	1.31 (33.3)	.22 Dia. w/ 41 dia. C'bore x .14 deep	3/8 - 16	200	Thermoplastic / Zinc-plated Brass	Black
C1938R*	2	2.06 (52.4)	.94 (23.8)	.69 (17.5)	.87 (22.2)	.69 (17.5)	.31 (7.9)	.94 (23.8)	.06 (1.6)	.06 (1.6)	1.31 (33.3)	.22 Dia. w/ 41 dia. C'bore x .14 deep	3/8 - 16	200	Thermoplastic / Zinc-plated Brass	Red
C1938-1*	2	2.06 (52.4)	.94 (23.8)	.69 (17.5)	.87 (22.2)	.69 (17.5)	.31 (7.9)	.94 (23.8)	.06 (1.6)	.06 (1.6)	1.31 (33.3)	.22 Dia. w/ 41 dia. C'bore x .14 deep	5/16 - 18	100	Thermoplastic / Tin-plated Brass	Black
C1938-1R*	2	2.06 (52.4)	.94 (23.8)	.69 (17.5)	.87 (22.2)	.69 (17.5)	.31 (7.9)	.94 (23.8)	.06 (1.6)	.06 (1.6)	1.31 (33.3)	.22 Dia. w/ 41 dia. C'bore x .14 deep	5/16 - 18	100	Thermoplastic / Tin-plated Brass	Red
C4044*	2	2.06 (52.4)	.87 (22.2)	.62 (15.9)	.62 (15.9)	1.12 (28.6)	.31 (7.9)	.94 (23.8)	.06 (1.6)	.06 (1.6)	1.31 (33.3)	.22 Dia. w/ 41 dia. C'bore x .14 deep	3/8 - 16	150	Thermoplastic / Zinc-plated Brass	Black
C4044-1*	2	2.06 (52.4)	.87 (22.2)	.62 (15.9)	.62 (15.9)	1.12 (28.6)	.31 (7.9)	.94 (23.8)	.06 (1.6)	.06 (1.6)	1.31 (33.3)	.22 Dia. w/ 41 dia. C'bore x .14 deep	3/8 - 16	150	Thermoplastic / Tin-plated Brass	Black
C4044-1R*	2	2.06 (52.4)	.87 (22.2)	.62 (15.9)	.62 (15.9)	1.12 (28.6)	.31 (7.9)	.94 (23.8)	.06 (1.6)	.06 (1.6)	1.31 (33.3)	.22 Dia. w/ 41 dia. C'bore x .14 deep	3/8 - 16	150	Thermoplastic / Tin-plated Brass	Red

Notes:

\*Feed-thru single stud type junction block  
Option of nuts and washers. Consult factory for more information.

continued on next page >>

Part	Fig.	A	B	C	D	E	F	G	H	J	K	L	M	Max. Torque (in-lbs)	Material	Color
C5898*	2	2.06 (52.4)	.94 (23.8)	.69 (17.5)	.87 (22.2)	.69 (17.5)	.31 (7.9)	.94 (23.8)	.06 (1.6)	.06 (1.6)	1.31 (33.3)	.22 Dia. w/ 41 dia. C'bore x .14 deep	3/8 - 16	150	Thermoplastic / Zinc-plated Brass	Red
C6344-2	2	2.06 (52.4)	.87 (22.2)	.62 (15.9)	.62 (15.9)	1.12 (15.9)	.31 (7.9)	None	.06 (1.6)	None	1.31 (33.3)	.22 Dia. w/ 41 dia. C'bore x .14 deep	1/2 - 20	150	Thermoplastic / Zinc-plated Brass	Black
C7020*	2	2.06 (52.4)	.94 (23.8)	.69 (17.5)	.88 (22.2)	.69 (17.5)	.31 (8.0)	1.25 (31.8)	.06 (1.6)	.06 (1.6)	1.31 (33.3)	.22 Dia. w/ 41 dia. C'bore x .14 deep	3/8 - 16	150	Thermoplastic / Zinc-plated Brass	Red
JB3816-2	2	2.12 (54.0)	.98 (24.9)	.62 (15.9)	.87 (22.2)	.69 (17.5)	.31 (7.9)	None	.06 (1.6)	None	1.37 (34.9)	.22 Dia. w/ .37 dia. C'bore x .14 deep	3/8 - 16	150	Thermoplastic / Zinc-plated Brass	Black
JB3816-3	2	2.12 (54.0)	.98 (24.9)	.62 (15.9)	.87 (22.2)	.69 (17.5)	.31 (7.9)	None	.06 (1.6)	None	1.37 (34.9)	.22 Dia. w/ .37 dia. C'bore x .14 deep	3/8 - 16	150	Thermoplastic / Zinc-plated Brass	Red
C2791*	3	2.06 (52.4)	.69 (17.5)	.44 (11.2)	.62 (15.9)	.69 (17.5)	.31 (7.9)	.69 (17.5)	.06 (1.6)	.06 (1.6)	1.31 (33.3)	.22 Dia. w/ 41 dia. C'bore x .14 deep	1/4 - 20	30	Thermoplastic / Zinc-plated Brass	Black
C2791-R*	3	2.06 (52.4)	.69 (17.5)	.44 (11.2)	.62 (15.9)	.69 (17.5)	.31 (7.9)	.69 (17.5)	.06 (1.6)	.06 (1.6)	1.31 (33.3)	.22 Dia. w/ 41 dia. C'bore x .14 deep	1/4 - 20	30	Thermoplastic / Zinc-plated Brass	Red
C2909*	3	2.06 (52.4)	.69 (17.5)	.44 (11.2)	.62 (15.9)	1.0 (25.4)	.31 (7.9)	.69 (17.5)	.06 (1.6)	.06 (1.6)	1.31 (33.3)	.22 Dia. w/ 41 dia. C'bore x .14 deep	10 - 32	24	Thermoplastic / Zinc-plated Brass	Black
C2909-1*	3	2.06 (52.4)	.69 (17.5)	.44 (11.2)	.62 (15.9)	1.0 (25.4)	.31 (7.9)	.69 (17.5)	.06 (1.6)	.06 (1.6)	1.31 (33.3)	.22 Dia. w/ 41 dia. C'bore x .14 deep	1/4 - 20	30	Thermoplastic / Zinc-plated Brass	Black
C7018*	3	2.06 (52.4)	.69 (17.5)	.44 (11.2)	.47 (11.9)	.69 (17.5)	.31 (7.9)	.53 (13.5)	.06 (1.6)	.06 (1.6)	1.31 (33.3)	.22 Dia. w/ 41 dia. C'bore x .14 deep	M6	55	Thermoplastic / Zinc-plated Brass	Black

Notes:

\*Feed-thru single stud type junction block  
Option of nuts and washers. Consult factory for more information.